

NIKE
Inground Light Series
SL2152C

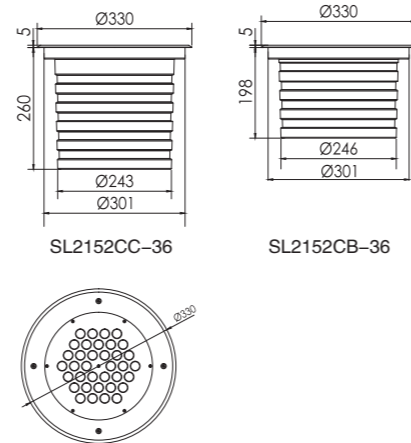

Specification

Product Code	SL2152CC-36	SL2152CB-36
LED Brand	CREE	CREE
LED Quantity	36pcs	36pcs
Rated Power	72W	56W
Input Voltage	DC24V/AC100-240V	DC24V/AC100-240V
Frequency Range	50/60Hz	50/60Hz
Color	RGB/Single	RGB/Single
Beam Angle	5° 8° 12.5° 20° 30° 45° 60° 15X30° 10X60°	
Control Mode	DMX512/CC	DMX512/CC
Life	50000H	50000H
Protection Grade	IP67	IP67
Ambient Temperature	- 25°C ~ 50°C	- 25°C ~ 50°C
Ambient Humidity	10% ~ 90%	10% ~ 90%

Distribution Curve Flux (SBC Case)

SL2130SA-24

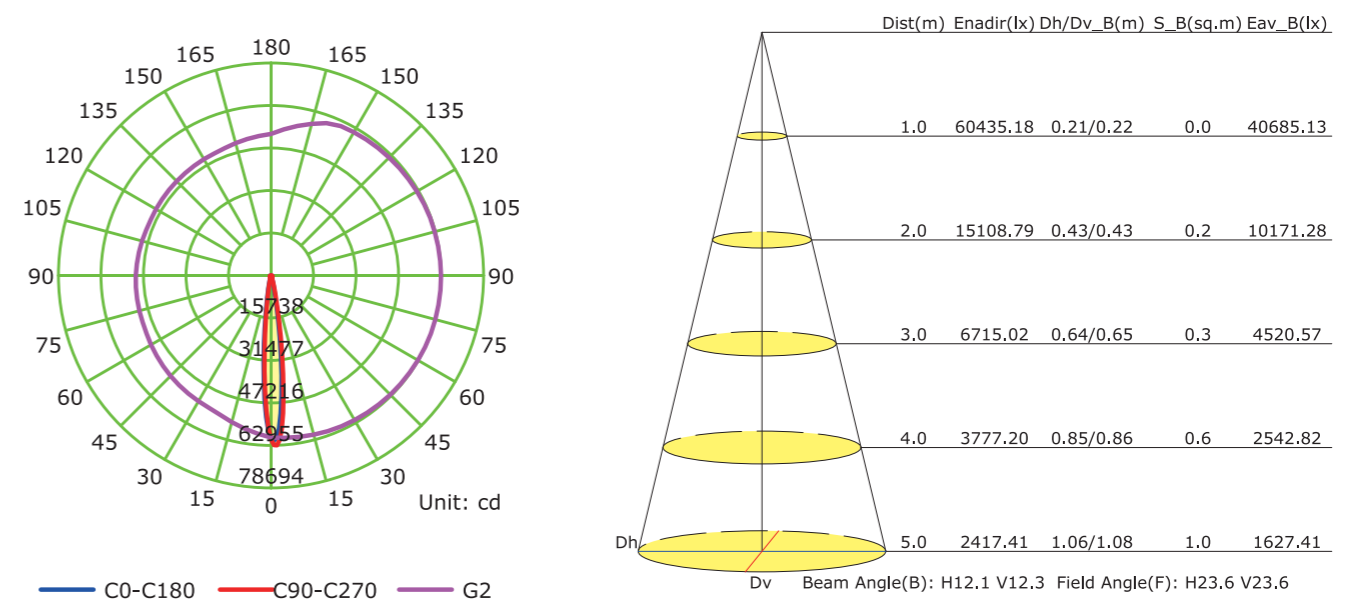

Product Introduction

- 1、 High power LED underground light, fashionable and beautiful appearance. The light body uses the design of increasing heat dissipation space, the buried barrel adopts aluminium alloy compression moulding forming. Surface with anodizing treatment has the stronger structure and anti-corrosion capability, that its thermal conductivity is 200 times higher than the normal project plastic's, meet the LED light body requirement for heat conduct to the outside of concrete and land, fully ensure the stability and long lifespan of LED fixture.
- 2、 Stainless steel faceplate, high pressure die casting light body, surface with electrostatic plastic coating. Lampshade adopts high strength toughened glass, resist the impact and friction.
- 3、 Adopt American CREE original LED light source, high flus output, excellent consistency of light color; Constant current driver with PWM gray control installed inside, RGB gray level reaches to 65,536 degree equally, make the light result much beautiful.
- 4、 Powerful DMX512 interface adopts high reliable bus connect, all has the function of automatic addressing.

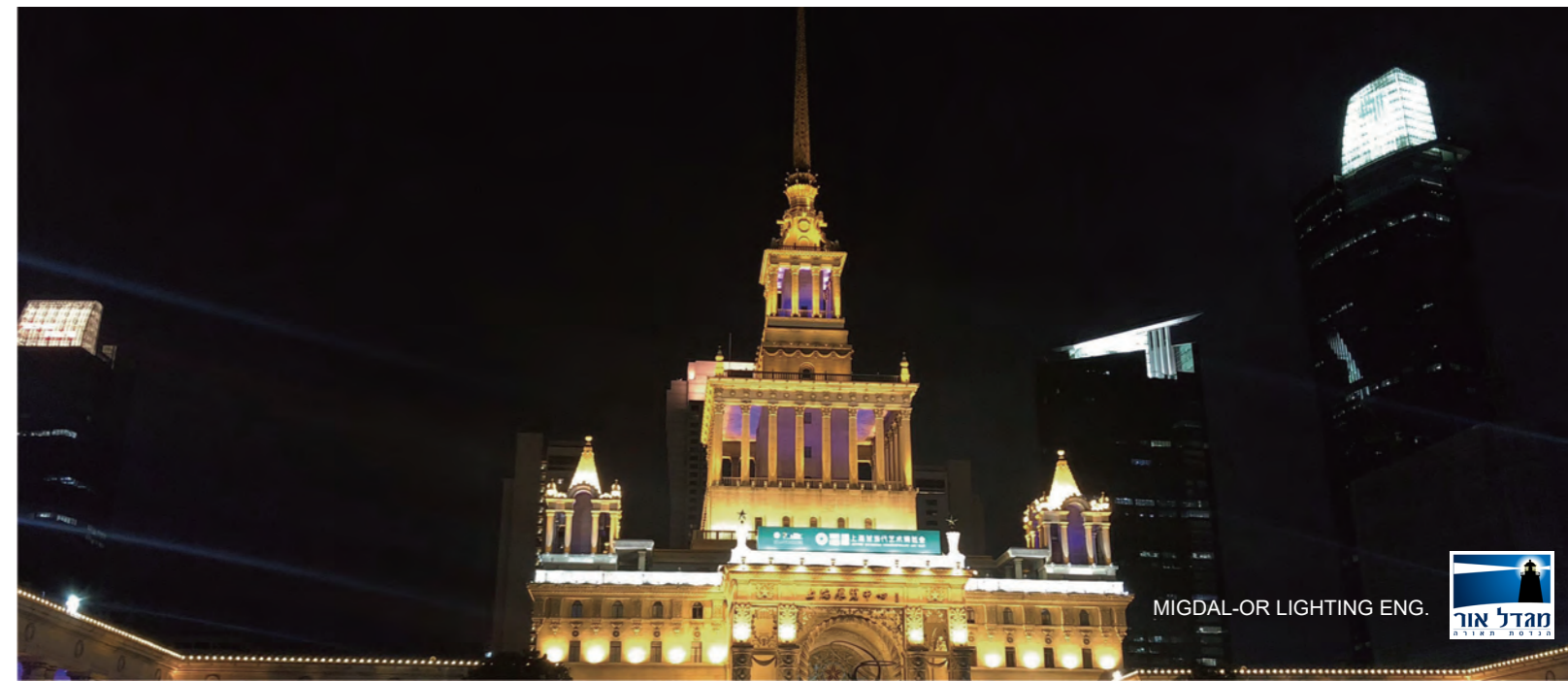

NIKE
Inground Light Series
SL2150C

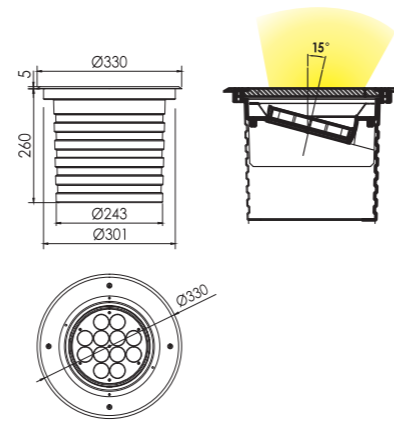

Specification

Product Code	SL2150CE-12	SL2150CD-12	SL2150CC-24	SL2150CB-24	SL2150CF-12
LED Brand	CREE	CREE	CREE	CREE	CREE RGBW 4 in 1
LED Quantity	12pcs	12pcs	24pcs	24pcs	12pcs
Rated Power	60W	42W	60W	42W	100W
Input Voltage	AC100-240V	AC100-240V	DC24V/AC100-240V	DC24V/AC100-240V	DC24V/AC100-240V
Frequency Range	50/60Hz	50/60Hz	50/60Hz	50/60Hz	50/60Hz
Color	Single	Single	RGB/Single	RGB/Single	RGBW
Beam Angle	3.5° 8° 12° 20° 30° 60° 10x70°		5° 12.5° 20° 30° 45°	60° 15X30° 10X60°	15° 20° 30° 15x60°
Control Mode	CC	CC	DMX512/CC	DMX512/CC	DMX512
Life	50000H	50000H	50000H	50000H	50000H
Protection Grade	IP67	IP67	IP67	IP67	IP67
Ambient Temperature	- 25°C ~ 50°C	- 25°C ~ 50°C	- 25°C ~ 50°C	- 25°C ~ 50°C	- 25°C ~ 50°C
Ambient Humidity	10% ~ 90%°	10% ~ 90%°	10% ~ 90%	10% ~ 90%	10% ~ 90%

Product Introduction

- 1 High power LED underground light, fashionable and beautiful appearance. The light body uses the design of increasing heat dissipation space, the buried barrel adopts aluminium alloy compression moulding forming. Surface with anodizing treatment has the stronger structure and anti-corrosion capability, that its thermal conductivity is 200 times higher than the normal project plastic's, meet the LED light body requirement for heat conduct to the outside of concrete and land, fully ensure the stability and long lifespan of LED fixture.
2. Stainless steel faceplate, high pressure die casting light body, surface with electrostatic plastic coating. Lampshade adopts high strength toughened glass, resist the impact and friction.
3. Adopt American CREE original LED light source, high flus output, excellent consistency of light color; Constant current driver with PWM gray control installed inside, RGB gray level reaches to 65,536 degree equally, make the light result much beautiful.
4. Powerful DMX512 interface adopts high reliable bus connect, all has the function of automatic addressing.



NIKE Inground Light Series SL2130C



SL2130S

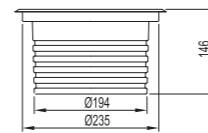
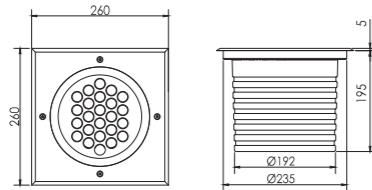

SL2130CA-24
SL2130CB-18
SL2130CA-18

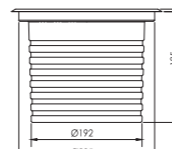
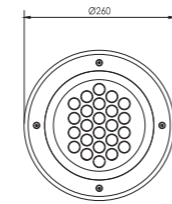

SL2130CB-24

Product Introduction

- 1、High power LED underground light, fashionable and beautiful appearance. The light body uses the design of increasing heat dissipation space, the buried barrel adopts aluminium alloy compression moulding forming. Surface with anodizing treatment has the stronger structure and anti-corrosion capability, that its thermal conductivity is 200 times higher than the normal project plastic's, meet the LED light body requirement for heat conduct to the outside of concrete and land, fully ensure the stability and long lifespan of LED fixture.
- 2、Stainless steel faceplate, high pressure die casting light body, surface with electrostatic plastic coating. Lampshade adopts high strength toughened glass, resist the impact and friction.
- 3、Adopt American CREE original LED light source, high flus output, excellent consistency of light color; Constant current driver with PWM gray control installed inside, RGB gray level reaches to 65,536 degree equally, make the light result much beautiful.
- 4、Powerful DMX512 interface adopts high reliable bus connect, all has the function of automatic addressing.

Specification

Product Code	SL2130CB-24	SL2130CA-24	SL2130CB-18	SL2130CA-18	SL2130CF-9
LED Brand	CREE	CREE	CREE	CREE	CREE RGBW 4 in 1
LED Quantity	24pcs	24pcs	18pcs	18pcs	9pcs
Rated Power	40W	30W	30W	21W	72W
Input Voltage	DC36V/AC100-240V	DC24V/AC100-240V	DC24V/AC100-240V	DC24V/AC100-240V	DC24V/AC100-240V
Frequency Range	50/60Hz	50/60Hz	50/60Hz	50/60Hz	50/60Hz
Color	RGB/Single	RGB/Single	RGB/Single	RGB/Single	RGBW
Beam Angle	5° 8° 12.5° 20° 30° 45° 60° 15X30° 10X60°				15° 20° 30° 15x60°
Control Mode	DMX512/CC	DMX512/CC	DMX512/CC	DMX512/CC	DMX512
Life	50000H	50000H	50000H	50000H	50000H
Protection Grade	IP67	IP67	IP67	IP67	IP67
Ambient Temperature	- 25°C ~ 50°C	- 25°C ~ 50°C	- 25°C ~ 50°C	- 25°C ~ 50°C	- 25°C ~ 50°C
Ambient Humidity	10% ~ 90%°	10% ~ 90%°	10% ~ 90%	10% ~ 90%	10% ~ 90%

Distribution Curve Flux (SBC Case)

SL2130CA-24

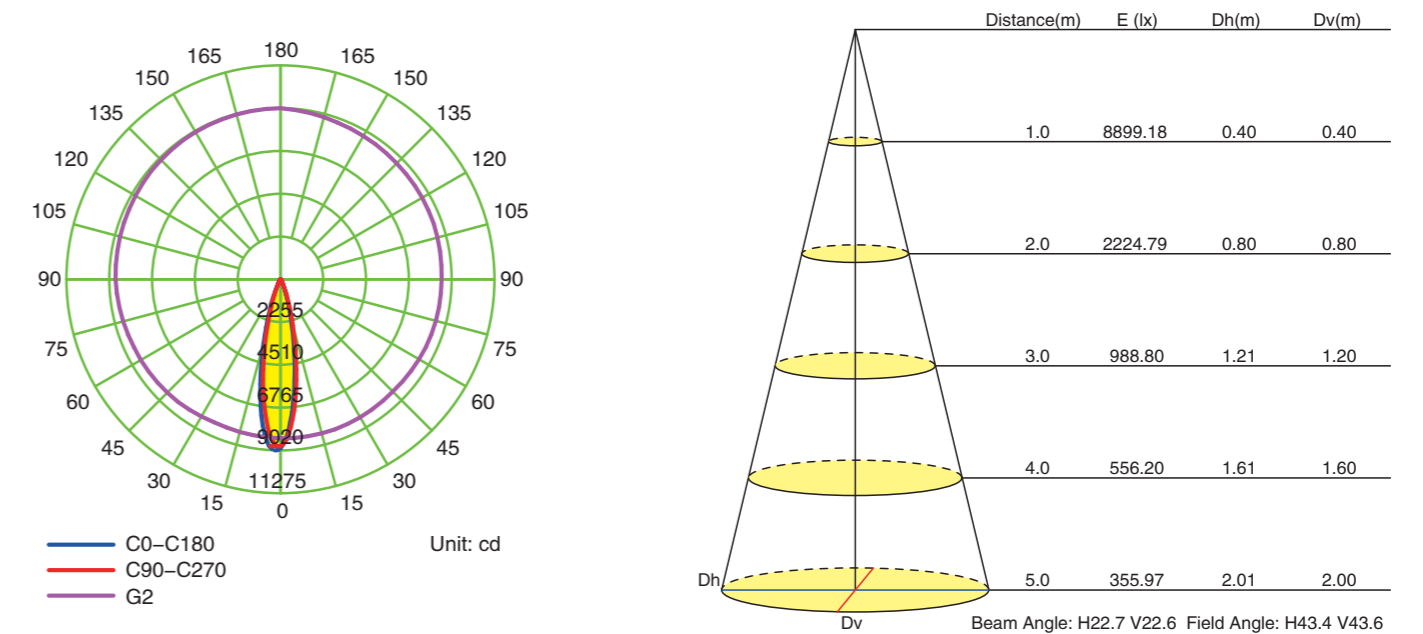

NIKE
Inground Light Series
SL2128C

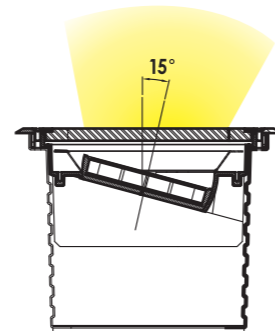

SL2128S

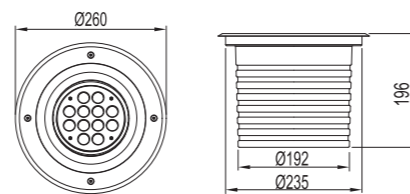
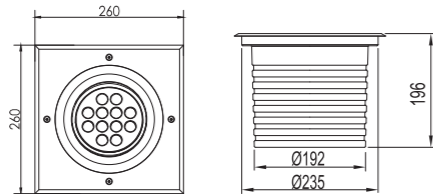

Specification

Product Code	SL2128CC-12	SL2128CA-12
LED Brand	CREE	CREE
LED Quantity	12pcs	12pcs
Rated Power	32W	14W
Input Voltage	DC24V/AC100-240V	DC24V/AC100-240V
Frequency Range	50/60Hz	50/60Hz
Color	RGB/Single	RGB/Single
Beam Angle	5° 8° 12.5° 20° 30° 45° 60° 15X30° 10X60°	
Control Mode	DMX512/CC	DMX512/CC
Life	50000H	50000H
Protection Grade	IP67	IP67
Ambient Temperature	- 25°C ~ 50°C	- 25°C ~ 50°C
Ambient Humidity	10% ~ 90%	10% ~ 90%



NIKE
Inground Light Series
SL2112C



Specification

Product Code	SL2112CB-12	SL2112CA-12
LED Brand	CREE	CREE
LED Quantity	12pcs	12pcs
Rated Power	22W	14W
Input Voltage	DC24V/AC100-240V	DC24V/AC100-240V
Frequency Range	50/60Hz	50/60Hz
Color	RGB/Single	RGB/Single
Beam Angle	5° 8° 12.5° 20° 30° 45° 60° 15X30° 10X60°	
Control Mode	DMX512/CC	DMX512/CC
Life	50000H	50000H
Protection Grade	IP67	IP67
Ambient Temperature	- 25°C ~ 50°C	- 25°C ~ 50°C
Ambient Humidity	10% ~ 90%	10% ~ 90%

Distribution Curve Flux (SBC Case)

SL2112CA-12

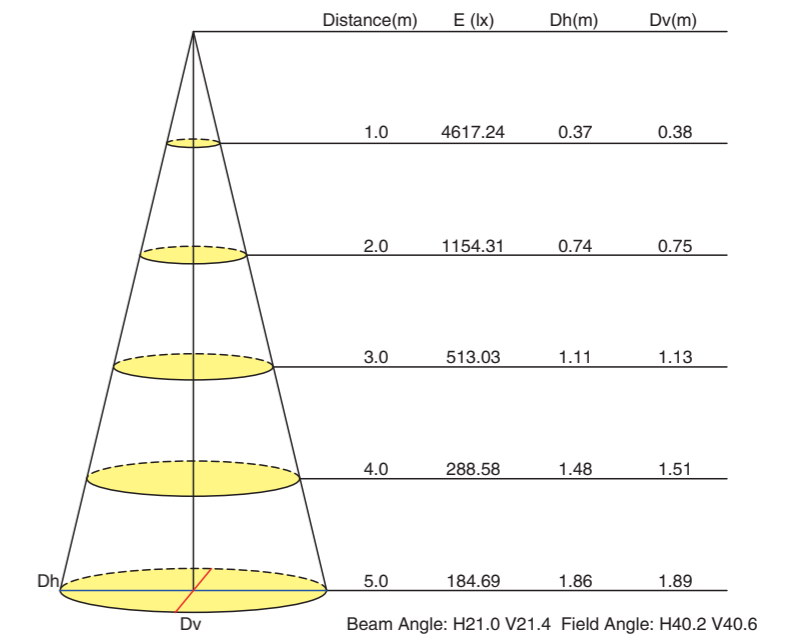
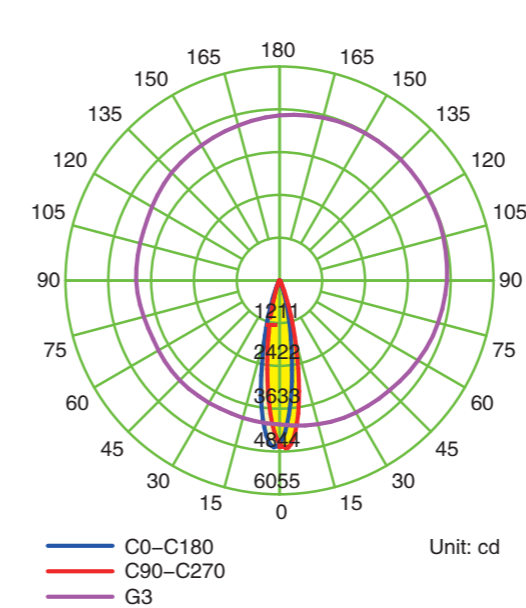

SL2112S

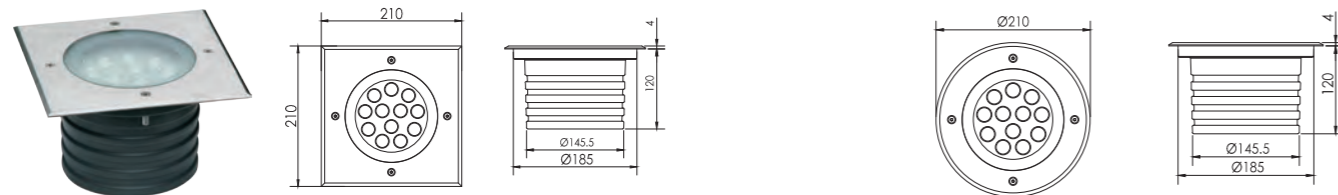

NIKE
Inground Light Series
SL2110C



Specification

Product Code	SL2110CC-7	SL2110CC-6
LED Brand	CREE	CREE
LED Quantity	7pcs	6pcs
Rated Power	16W	14W
Input Voltage	AC100-240V	DC24V/AC100-240V
Frequency Range	50/60Hz	50/60Hz
Color	Single	RGB
Beam Angle	5° 8° 12.5° 20° 30° 45° 60° 15X30° 10X60°	
Control Mode	CC	DMX512
Life	50000H	50000H
Protection Grade	IP67	IP67
Ambient Temperature	- 25°C ~ 50°C	- 25°C ~ 50°C
Ambient Humidity	10% ~ 90%	10% ~ 90%

SL2110S

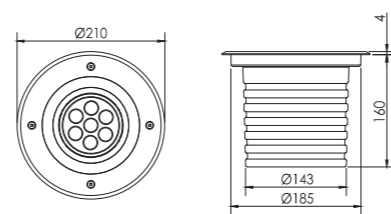
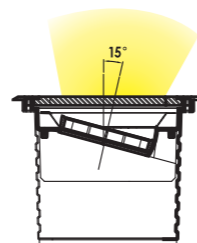
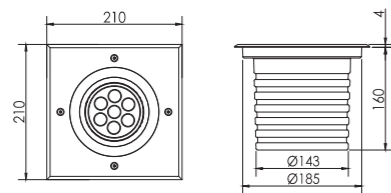

NIKE
Inground Light Series
SL2109C

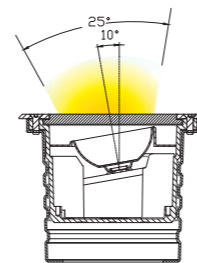
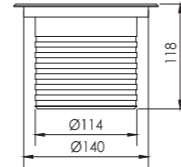
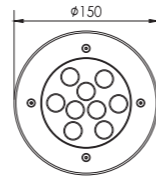

Specification

Product Code	SL2109CB-9	SL2109CA-9	SL2109C-C12
LED Brand	CREE	CREE	CREE COB
LED Quantity	9pcs	9pcs	1pc
Rated Power	16W	11W	12W
Input Voltage	DC12V/AC100-240V	DC12V/AC100-240V	AC100-240V
Frequency Range	50/60Hz	50/60Hz	50/60Hz
Color	RGB/Single	RGB/Single	Single
Beam Angle	5° 8° 12.5° 20° 30° 45° 60°		25° Asy. 10°
Control Mode	DMX512/CC	DMX512/CC	CC
Life	50000H	50000H	50000H
Protection Grade	IP67	IP67	IP67
Ambient Temperature	- 25°C ~ 50°C	- 25°C ~ 50°C	- 25°C ~ 50°C
Ambient Humidity	10% ~ 90%	10% ~ 90%	10% ~ 90%

Distribution Curve Flux (SBC Case)

SL2109CA-9

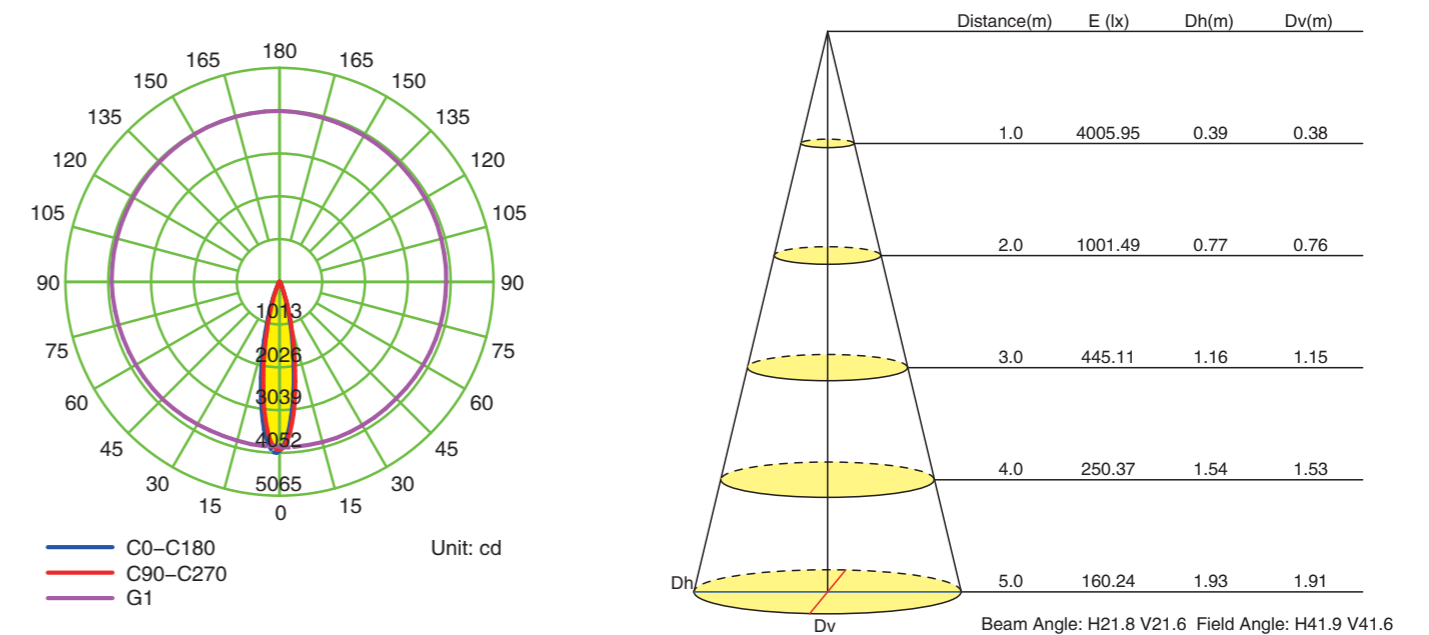

SL2109S

SL2109C-C12

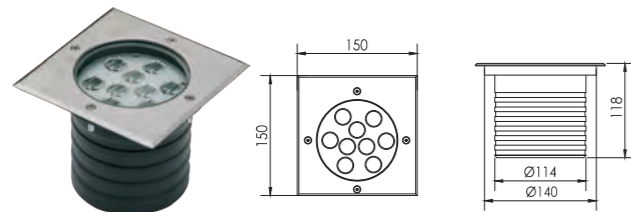

NIKE
Inground Light Series
SL2106C

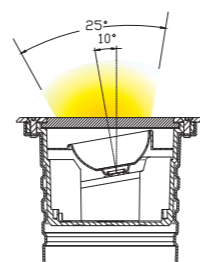
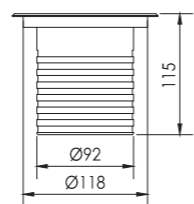
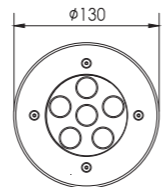

SL2106S

SL2106C-C8

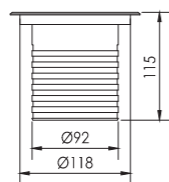
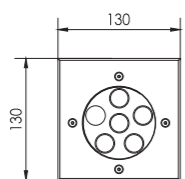

Specification

Product Code	SL2106CB-6	SL2106CA-6	SL2106C-C8
LED Brand	CREE	CREE	CREE COB
LED Quantity	6pcs	6pcs	1pc
Rated Power	12W	7W	8W
Input Voltage	DC12V/AC100-240V	DC12V/AC100-240V	AC100-240V
Frequency Range	50/60Hz	50/60Hz	50/60Hz
Color	RGB/Single	RGB/Single	Single
Beam Angle	5° 8° 12.5° 20° 30° 45° 60°		25° Tilt. 10°
Control Mode	DMX512/CC	DMX512/CC	CC
Life	50000H	50000H	50000H
Protection Grade	IP67	IP67	IP67
Ambient Temperature	- 25°C ~ 50°C	- 25°C ~ 50°C	- 25°C ~ 50°C
Ambient Humidity	10% ~ 90%	10% ~ 90%	10% ~ 90%

Distribution Curve Flux (SBC Case)

SL2106CA-6

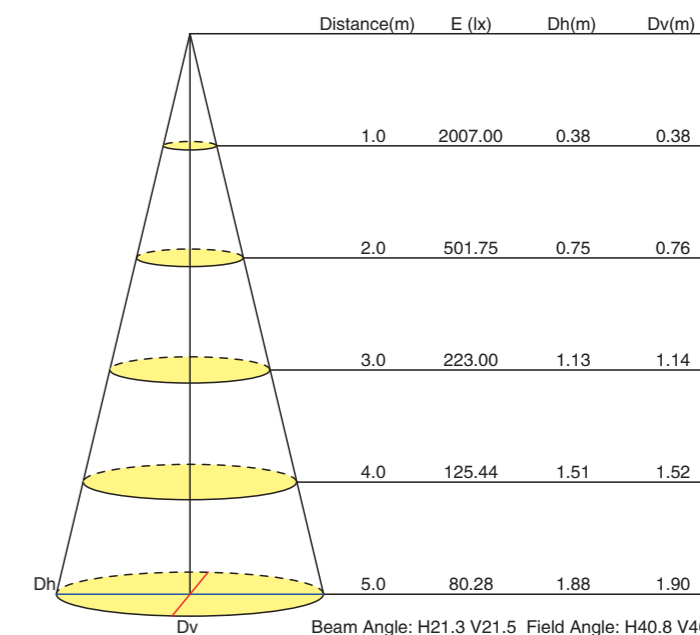
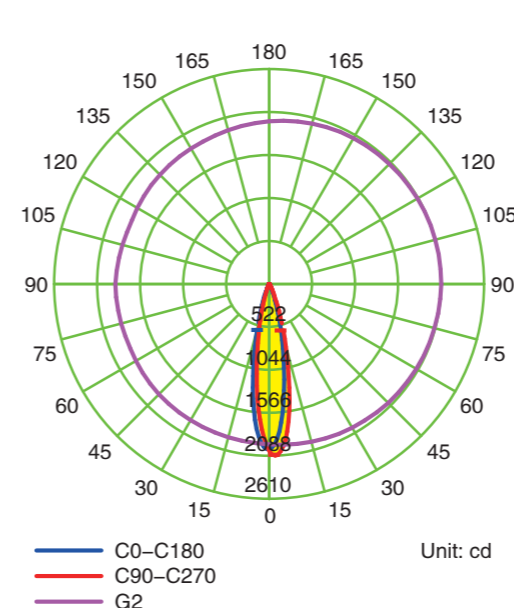

NIKE
Inground Light Series
SL2103C

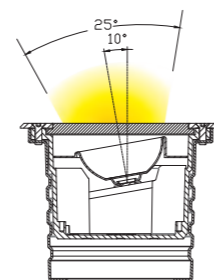
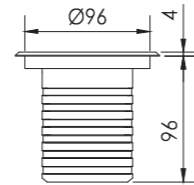
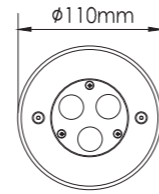

SL2103S

SL2103C-C6

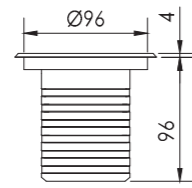
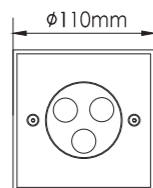

Specification

Product Code	SL2103CB-3	SL2103CA-3	SL2103C-C6
LED Brand	CREE	CREE	CREE COB
LED Quantity	3pcs	3pcs	1pc
Rated Power	6W	3.5W	6W
Input Voltage	DC12V/AC100-240V	DC12V/AC100-240V	AC100-240V
Frequency Range	50/60Hz	50/60Hz	50/60Hz
Color	RGB/Single	RGB/Single	Single
Beam Angle	5° 8° 12.5° 20° 30° 45° 60°		25° Tilt. 10°
Control Mode	PWM/CC	PWM/CC	CC
Life	50000H	50000H	50000H
Protection Grade	IP67	IP67	IP67
Ambient Temperature	- 25°C ~ 50°C	- 25°C ~ 50°C	- 25°C ~ 50°C
Ambient Humidity	10% ~ 90%	10% ~ 90%	10% ~ 90%

Distribution Curve Flux (SBC Case)

SL2103CA-3

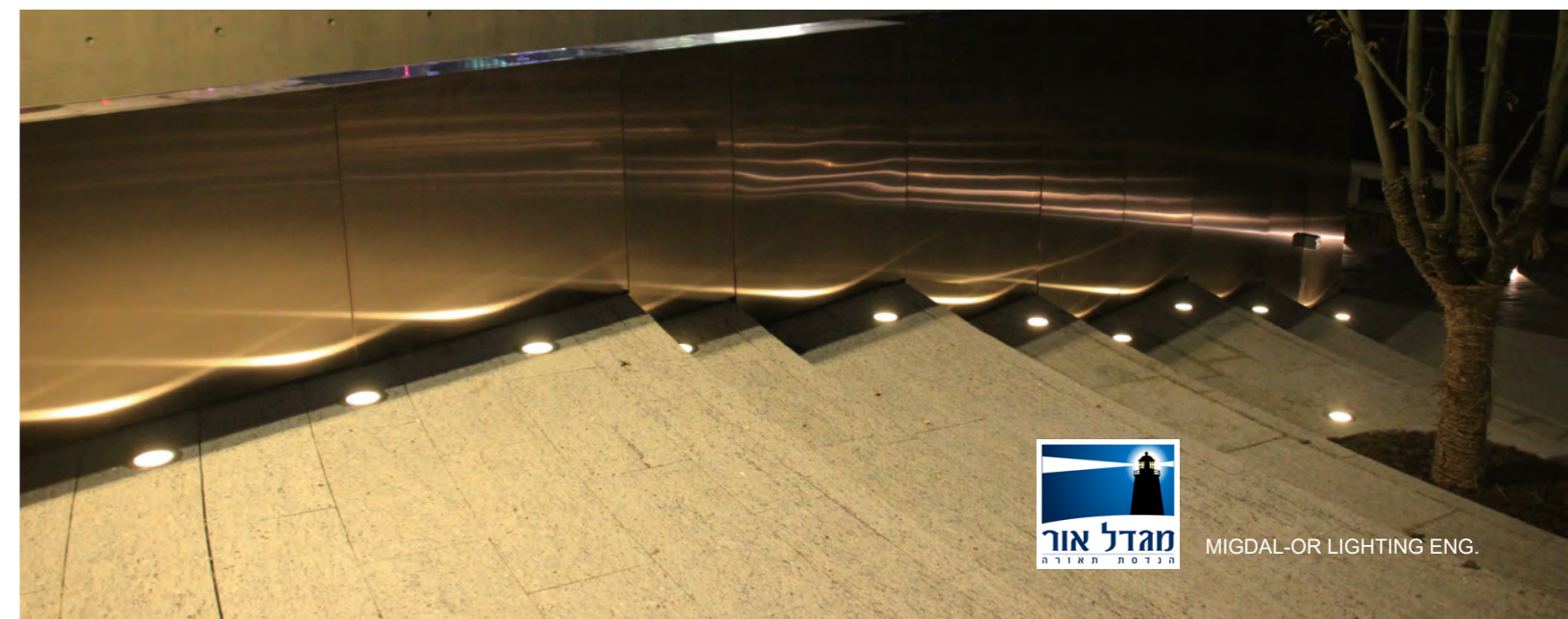
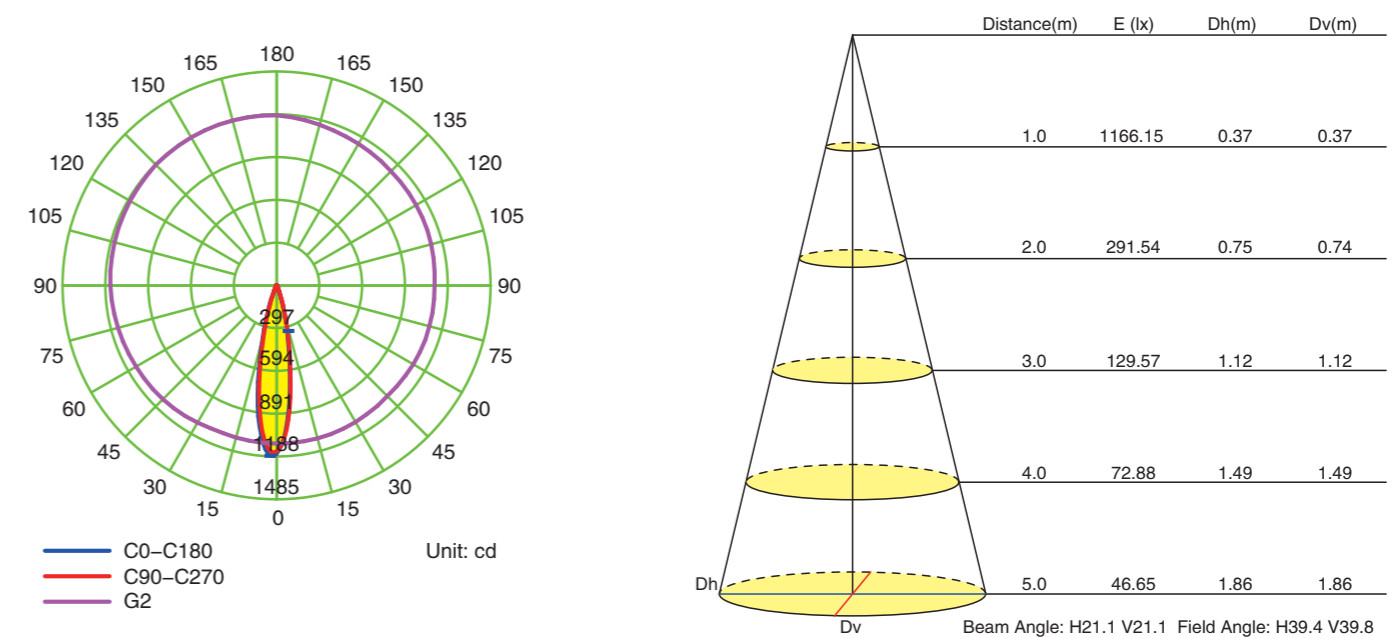

NIKE
Inground Light Series
SL2102

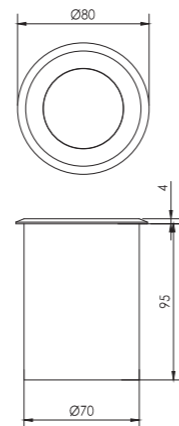

Specification

Product Code	SL2102A-3	SL2102C-1
LED Brand	CREE	CREE
LED Quantity	3pcs	1pc
Rated Power	4W	3W
Input Voltage	DC24V /DC12V	DC24V/AC100-240V
Frequency Range	/	50/60Hz
Color	RGB	Single
Beam Angle	120°	120°
Control Mode	DMX512	CC
Life	50000H	50000H
Protection Grade	IP67	IP67
Ambient Temperature	- 25°C ~ 50°C	- 25°C ~ 50°C
Ambient Humidity	10% ~ 90%	10% ~ 90%



NIKE
Inground Light Series
SL2101

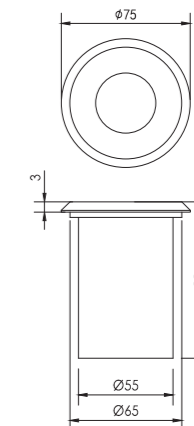

Specification

Product Code	SL2101A-1
LED Brand	CREE
LED Quantity	1pc
Rated Power	1.5W
Input Voltage	DC24V/AC100-240V
Frequency Range	50/60Hz
Color	Single
Beam Angle	25° 120°
Control Mode	CC
Life	50000H
Protection Grade	IP67
Ambient Temperature	- 25°C ~ 50°C
Ambient Humidity	10% ~ 90%



NIKE
Inground Light Series
SL21005

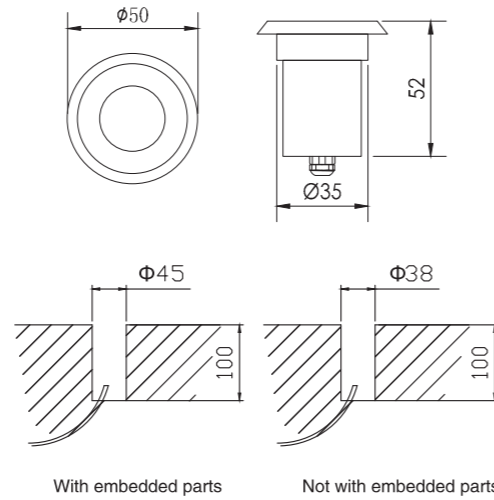

Specification

Product Code	SL21005A-1
LED Brand	CREE
LED Quantity	1pc
Rated Power	1.5W
Input Voltage	DC12V / DC24V / AC100-240V
Frequency Range	50/60Hz
Color	RGB/Single
Beam Angle	120° 12.5° 20° 30° 45°
Control Mode	DMX512/PWM/CC
Life	50000H
Protection Grade	IP67
Ambient Temperature	- 25°C ~ 50°C
Ambient Humidity	10% ~ 90%



NIKE
Inground Light Series
SL21003

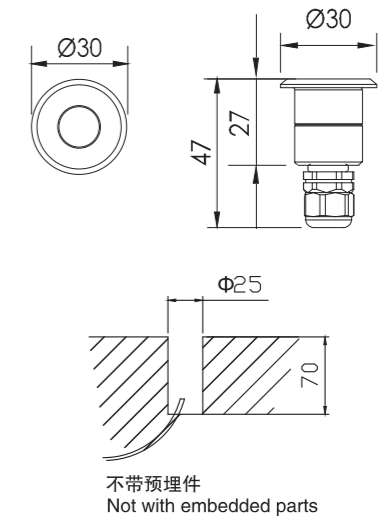

Specification

Product Code	SL21003A-1
LED Brand	EPISTAR
LED Quantity	1pc
Rated Power	0.5W
Input Voltage	DC12V/DC24V
Frequency Range	/
Color	Single
Beam Angle	120°
Control Mode	CC
Life	50000H
Protection Grade	IP67
Ambient Temperature	- 25°C~50°C
Ambient Humidity	10%~90%



NIKE
Inground Light Series
SL5119

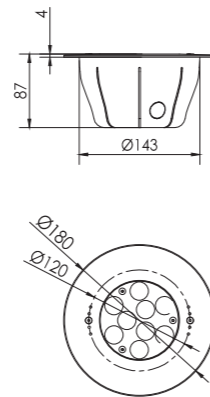

NIKE
Inground Light Series
SL5116

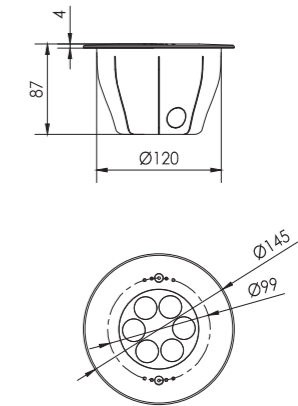

Specification

Product Code	SL5119B-9	SL5119A-9
LED Brand	CREE	CREE
LED Quantity	9pcs	9pcs
Rated Power	16W	10W
Input Voltage	DC12V /DC24V	DC12V /DC24V
Frequency Range	/	/
Color	RGB/Single	RGB/Single
Beam Angle	5° 8° 12.5° 20° 30° 45°	
Control Mode	DMX512/CC	DMX512/CC
Life	50000H	50000H
Protection Grade	IP68	IP68
Ambient Temperature	- 25°C ~ 50°C	- 25°C ~ 50°C
Ambient Humidity	10% ~ 90%	10% ~ 90%

Specification

Product Code	SL5116B-6	SL5116A-6
LED Brand	CREE	CREE
LED Quantity	6pcs	6pcs
Rated Power	12W	7W
Input Voltage	DC12V /DC24V	DC12V /DC24V
Frequency Range	/	/
Color	RGB/Single	RGB/Single
Beam Angle	5° 8° 12.5° 20° 30° 45°	
Control Mode	DMX512/CC	DMX512/CC
Life	50000H	50000H
Protection Grade	IP68	IP68
Ambient Temperature	- 25°C ~ 50°C	- 25°C ~ 50°C
Ambient Humidity	10% ~ 90%	10% ~ 90%

