



NEW PRODUCTS

APOLLO . PANEL LIGHT

LED LIGHTING

Visual
comfort

Modular
Design

126/116
lm/W

UGR
16

~~FLICKER~~

UGR
16

5
years warranty

APOLLO . PANEL LIGHT

Features:

- Modular Design: 1 pair of light module with different frames fit all European ceiling grid.
- Less inventory and risk, faster time to projects, allow variety of ceiling grid size
- Glare free: UGR<16, luminance limits @65°<1000cd/m , EN 12464-1: 2011 compliant
- High efficacy: Up to 126lm/W(Pro), or 100lm/W(Standard)
- More useful light: over 90% useful lumen in cone 90°(zonal lumen)
- Dimming: Non-dimming, DALI and 1-10V dimming(only for Pro.)
- Class II,SELV, High Power Factor over 0.95
- Non-flicker design(only for Pro).
- Aluminum passive cooling, TcLED<61°C(Ta=25°C)
- Installation: Recessed/Pendant mounted
- Direct replacement for T8- 3x18W/4X18W; T5- 3x14W/4X14W
- Up to 65% energy saving, 3 times longer lifespan compared to fluorescent lamps.

PARAMETERS

Lumen(lm):	3600(Pro); 3400(Standard)	Power(W):	28(Pro); 30(Standard)
Input Voltage(VAC):	220-240	Heat sink:	Aluminum
Efficacy(lm/W):	126(Pro); 116(Standard)	Lifespan(hrs):	50,000
LED Chips	2x63pcs Epistar SMD 2835	CRI:	82
Working Temp:	-20-40°C	Beam Angle:	85°x70°

Cut-out: To fit all Europe ceiling T grid:600*600 / 625*625、300*1200、600*1200



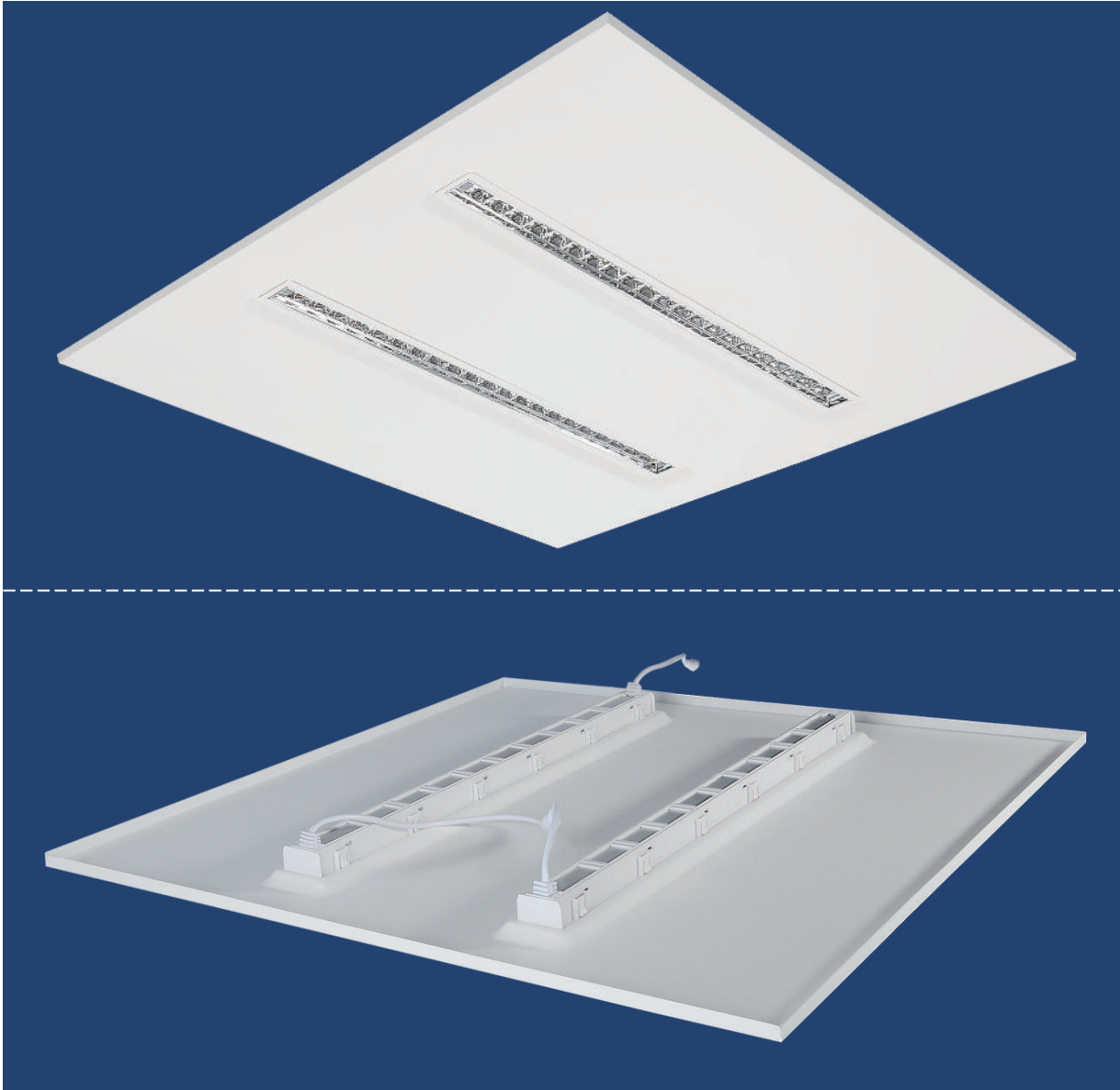

Installation

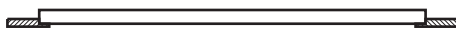

Recessed



Pendent

Dimension(mm)

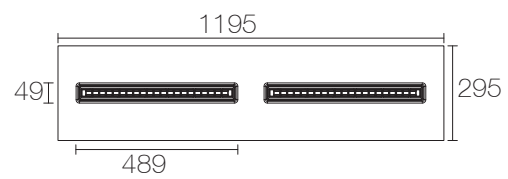
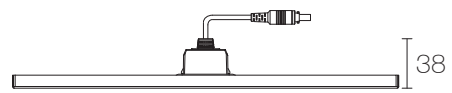
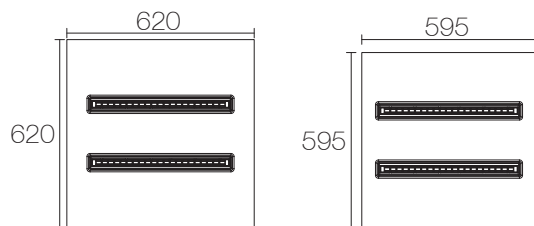

APOLLO . PANEL LIGHT

OPTICS DESIGN

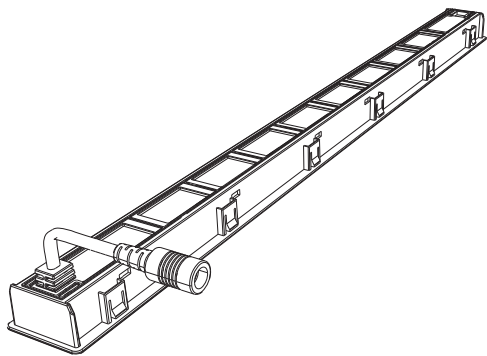
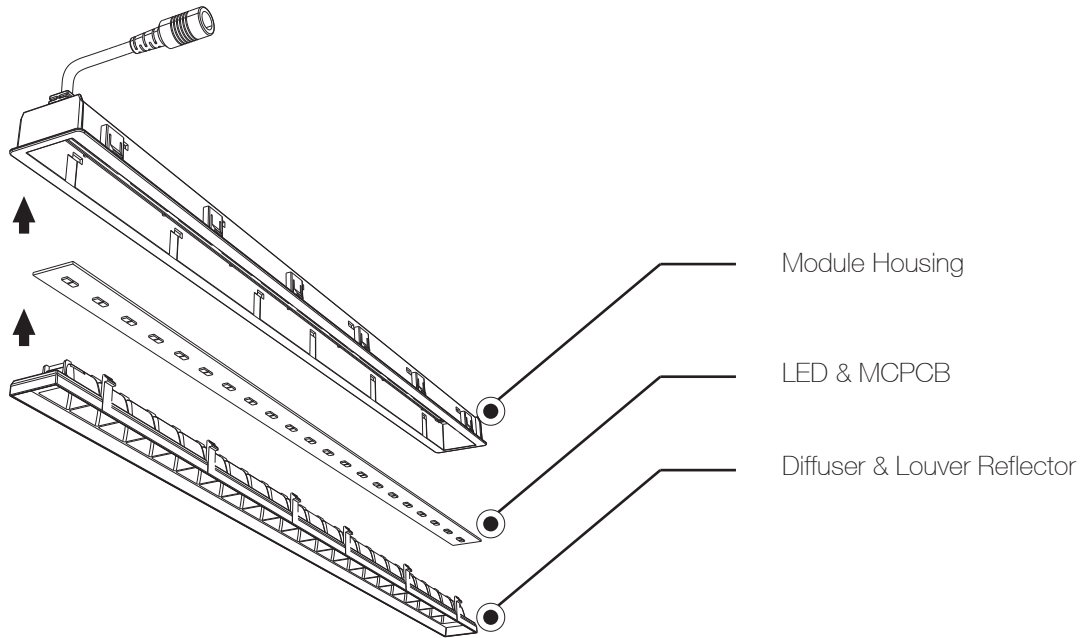

ZONAL LUMEN SUMMARY

Zone	#Fixt
0-30	51.16%
0-40	80.18%
0-60	99.36%
0-90	99.99%
0-120	99.99%
0-180	100%



APOLLO . PANEL LIGHT

LIGHT DISTRIBUTION

Kinglumi Apollo Panel light

Fluorescent Modular

Flat LED Panel

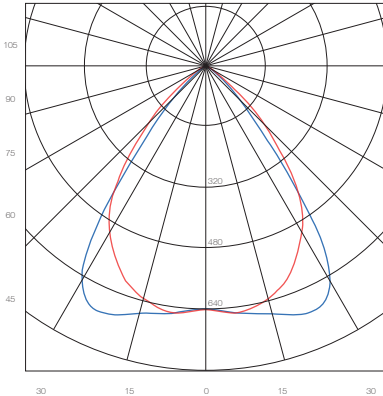

K&L Apollo Panel 4000K

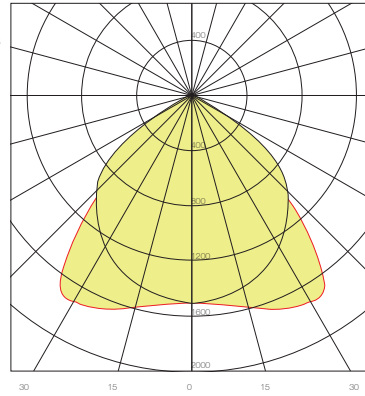

Philips TBS262 4xTL5-14W 840 HFS M6

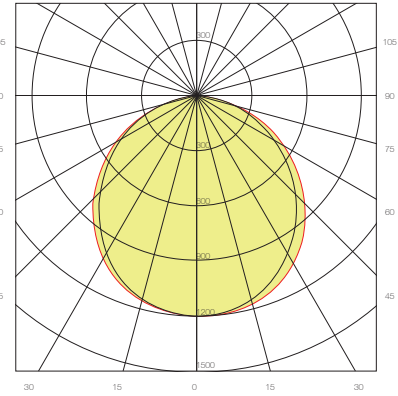

40W 600x600 NW LED panel light Eco2

Symmetrical light distribution with a batwing.

UGR Table

At application: (4H,8H), Reflection (70%,50%,20%)

Standard Version: $UGR \leq 14$

Pro Version: $UGR \leq 15$

UGR table of Pro version 595*595 3600lm

Illumination assessment according UGR											
Rf of Ceiling		70	70	50	50	30	70	70	50	50	30
Rf of Wall		50	30	50	30	30	50	30	50	30	30
Rf of Floor		20	20	20	20	20	20	20	20	20	20
Room dimensions		Viewed crosswise					Viewed endwise				
X	Y										
2H	2H	10.73	11.85	11.10	12.16	12.47	14.94	16.05	15.30	16.36	16.67
	3H	10.55	11.53	10.94	11.87	12.22	14.76	15.74	15.14	16.07	16.42
	4H	10.46	11.37	10.86	11.72	12.09	14.66	15.57	15.06	15.92	16.29
	6H	10.38	11.21	10.80	11.58	11.98	14.58	15.41	15.00	15.79	16.18
	8H	10.31	11.10	10.73	11.48	11.89	14.51	15.30	14.93	15.69	16.09
4H	12H	10.24	10.99	10.67	11.38	11.80	14.44	15.19	14.87	15.59	16.00
	2H	10.51	11.41	10.91	11.76	12.13	14.66	15.57	15.06	15.92	16.29
	3H	10.29	11.04	10.72	11.43	11.85	14.45	15.19	14.87	15.59	16.00
	4H	10.23	10.87	10.66	11.29	11.74	14.38	15.02	14.82	15.45	15.90
	6H	10.09	10.66	10.56	11.11	11.56	14.25	14.81	14.72	15.26	15.72
8H	8H	10.03	10.56	10.52	11.01	11.49	14.19	14.71	14.67	15.17	15.64
	12H	9.98	10.47	10.47	10.92	11.43	14.14	14.62	14.63	15.07	15.59
	4H	10.03	10.56	10.52	11.01	11.49	14.19	14.71	14.67	15.17	15.64
	6H	9.88	10.31	10.38	10.79	11.30	14.03	14.47	14.54	14.95	15.46
	8H	9.86	10.23	10.39	10.75	11.25	14.02	14.39	14.55	14.91	15.40
12H	12H	9.80	10.10	10.34	10.61	11.13	13.96	14.26	14.50	14.77	15.29
	4H	9.98	10.47	10.47	10.92	11.43	14.14	14.62	14.63	15.07	15.59
	6H	9.86	10.23	10.39	10.75	11.25	14.02	14.39	14.55	14.91	15.40
8H	9.80	10.10	10.34	10.61	11.13	13.96	14.26	14.50	14.77	15.29	
Variation with the observer position at spacings:											
S = 1.0H		2.2/-6.7					4.6/-25.5				
S = 1.5H		4.1/-21.5					6.4/-29.0				
S = 2.0H		6.1/-28.6					8.4/-29.5				
Standard tables:		BK0					BK0				
Uncorrected UGR		-4.0					-8.2				

Lux distance Curve

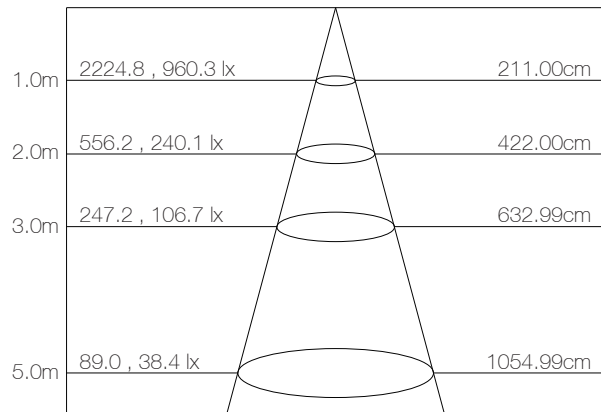

Max , Ave Beam angle of C120 plane 84x67

UGR calculation is based on CIE Publ. 117 , S/H = 0.25

APOLLO . PANEL LIGHT

LUMINANCE LIMITS

According to EN12464-2011 part 4.9.2, Light can lower the contrast of the presentation on a DSE. The Table 1 gives the limits of the average luminaire luminance at elevation angles of 65° and above from the downward vertical, radially around the luminaires, for work stations where display screens which are vertical or inclined up to 15° tilt angle are used.

Table 1 — Average luminance limits of luminaires, which can be reflected in flat screens

Screen high state luminance	High luminance screen $L > 200 \text{ cd}\cdot\text{m}^{-2}$	Medium luminance screen $L \leq 200 \text{ cd}\cdot\text{m}^{-2}$
Case A (positive polarity and normal requirements concerning colour and details of the shown information, as used in office, education, etc.)	$\leq 3\,000 \text{ cd}\cdot\text{m}^{-2}$	$\leq 1\,500 \text{ cd}\cdot\text{m}^{-2}$
Case B (negative polarity and/or higher requirements concerning colour and details of the shown information, as used for CAD colour inspection, etc.)	$\leq 1\,500 \text{ cd}\cdot\text{m}^{-2}$	$\leq 1\,000 \text{ cd}\cdot\text{m}^{-2}$

NOTE Screen high state luminance (see EN ISO 9241-302) describes the maximum luminance of the white part of the screen and this value is available from the manufacturer of the screen.

Glare Table

Glare	Quality	Service Values Illuminance(lx)							
		a	b	c	d	e	f	g	h
1.15	A	2000	1000	500	≤ 300				
1.5	B		2000	1000	500	≤ 300			
1.85	C			2000	1000	500	≤ 300		
2.2	D				2000	1000	500	≤ 300	
2.55	E					2000	1000	500	≤ 300
		a	b	c	d	e	f	g	h

Luminance Limiting Curve luminance limits @65° < 1000cd/m

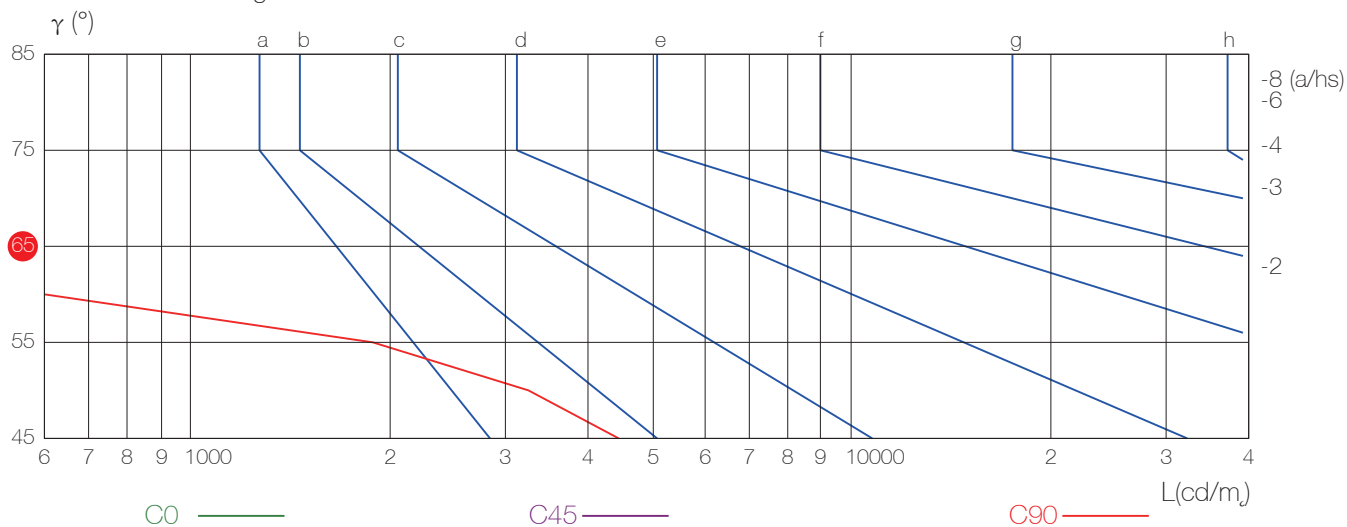



Professional | Unique
LED LIGHTING SOLUTIONS

Contact Sales Team
office@migdal-or.org

Tel: 04-8525244 Fax: 04-8525245
WWW.MIGDAL-OR.ORG